

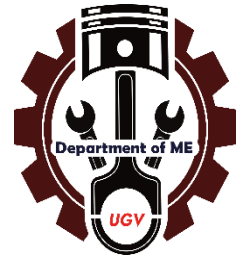

LAB MANUAL

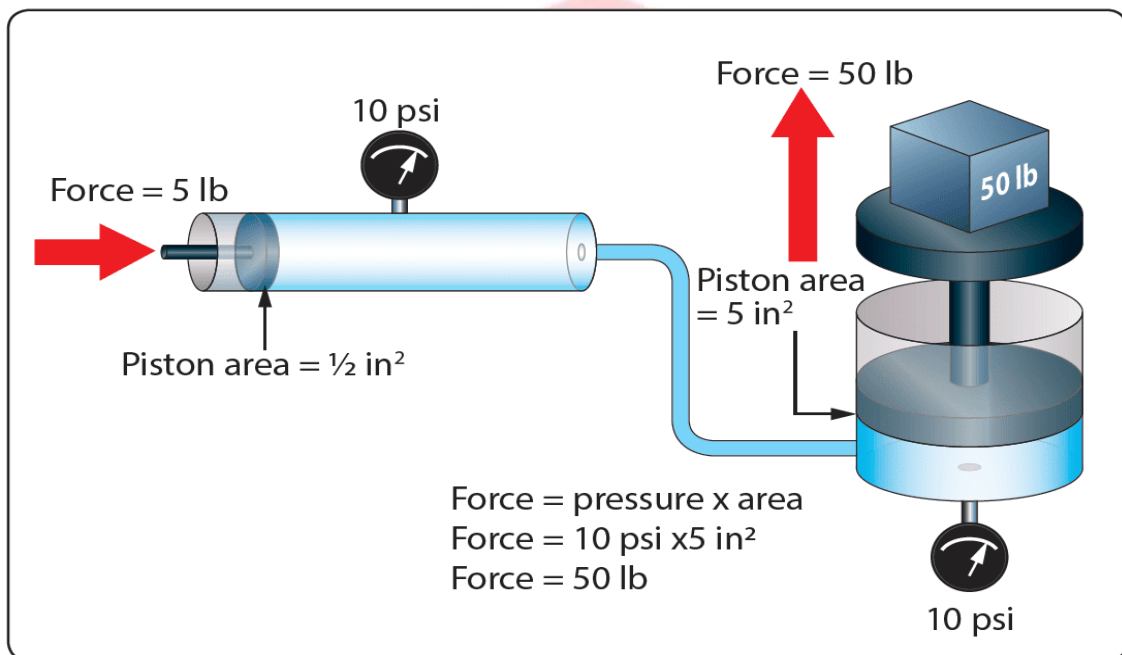

Fluid Mechanics-II Lab Course Code: ME-324



University of Global Village (UGV), Barishal

Department of Mechanical Engineering

UNIVERSITY OF GLOBAL VILLAGE

Prepared by

Md. Naeem Hosen Hredoy

Lab Instructor

Department of Mechanical

Course Name: Fluid Mechanics-II Lab

| | |
|---------------------------------------|----------------|
| Course Teacher: Md.Naeem Hosen Hredoy | CREDIT:01 |
| Course Code: ME-324 | TOTAL MARKS:50 |
| TOTAL Class : 17 Nos | CIE MARKS: 30 |
| Class Hours : 85 Hours | SEE MARKS: 20 |

Course Learning Outcomes (CLOs): After completing this course successfully, the students will be able to-

- CLO 1. Understand** the fundamental principles of fluid mechanics.
- CLO 2. Design** simple experiments related to fluid mechanics.
- CLO 3. Apply** the principles of fluid mechanics to solve engineering problems.
- CLO 4. Calculate** fluid properties and flow parameters.
- CLO 5. Analyze** experimental data and results.
- CLO 6. Generate** hypotheses and test them through experimentation.

UNIVERSITY OF GLOBAL VILLAGE

| Sr No | Content of Course | Hours | CLOs |
|-------|---|-------|-----------|
| 1 | Center of Pressure | 10 | CLO1 |
| 2 | Verification of Bernoulli's Theorem | 10 | CLO1,CLO3 |
| 3 | Flow through Venturi meter | 10 | CLO1,CLO3 |
| 4 | Flow through an Orifice | 10 | CLO1,CLO6 |
| 5 | Flow through an External Cylindrical Mouthpiece | 10 | CLO2,CLO5 |
| 6 | Flow over a sharp crested rectangular weir | 05 | CLO3 |
| 7 | Flow over a V-notch | 10 | CLO,CLO3 |
| 8 | Fluid Friction in a pipe | 10 | CLO2,CLO3 |
| 9 | Head Loss Due to Pipe Fittings | 10 | CLO5,CLO6 |

Reference Book :

1. Fluid Mechanics by Yunus Cengel, Jhon Cimbala, Tata Macgraw Hill, New Delhi.
2. Fluid Mechanics by R. J. Garde, A.J Mirajgaonkar, SCITECH Publication.
3. Fluid Mechanics by Streeter & Wylie, Tata McGraw Hill.
4. Fluid Mechanics by Dr. A. K. Jain, Khanna Publishers.
5. Fluid Mechanics by K. Subramanya, McGraw Hill.
6. Fluid Mechanics by Frank White, McGraw Hill.

ASSESSMENT PATTERN

**CIE- Continuous Internal
Evaluation**

**(20 Marks) SEE- Semester End
Examination (30 Marks)**

SEE- Semester End Examination (50 Marks) (should be converted in actual marks (30))

| Bloom's Category Cognitive | Tests (20) |
|--------------------------------------|-------------------|
| Remember | 05 |
| Understand | 07 |
| Apply | 08 |
| Analyze | 07 |
| Evaluate | 08 |
| Create | 05 |

| Bloom's Category Psychomotor | Practical Test (30) |
|--|----------------------------|
| Imitation | 10 |
| Manipulation | 5 |
| Precision | 5 |
| Articulation | 5 |
| Naturalization | 5 |

CIE- Continuous Internal Evaluation (40 Marks) (should be converted in actual marks (20))

| Bloom's Category Marks (out of 60) | Lab Report (10) | Continuous lab performance (10) | Presentation & Viva (10) | External Participation in Curricular/Co-Curricular Activities (10) |
|---|------------------------|--|-------------------------------------|---|
| Remember | | | 02 | Attendance 10 |
| Understand | 05 | 04 | 03 | |
| Apply | | 02 | | |
| Analyze | | 02 | | |
| Evaluate | 05 | 02 | | |
| Create | | | 05 | |

Course plan specifying content, CLOs, teaching learning and assessment strategy mapped with CLOs

| Week | Topic | Teaching-Learning Strategy | Assessment Strategy | Corresponding CLOs |
|-------|---|---|--------------------------------|--------------------|
| 1 | Center of Pressure | Conduct practical sessions with lab equipment. | Quiz, Written Exam | CLO1 |
| 2,3 | Verification of Bernoulli's Theorem | Provide ample practice time for each skill. | Practical Assessments, Quiz | CLO1,CLO2 |
| 4,5 | Flow through Venturi meter | Provide step-by-step explanations and demonstrations. | Performance-Based Assessments | CLO1,CLO3 |
| 6,7 | Flow through an Orifice | Pre-Lab Instructions. | Skill Tests | CLO1,CLO5 |
| 8,9 | Flow through an External Cylindrical Mouthpiece | Explain theory and objectives before experiments. | Project, Hands on Practice | CLO2,CLO3 |
| 10,11 | Flow over a sharp crested rectangular weir | Experiment, Demonstration | Proper equipment setup and use | CLO1 |
| 12,13 | Flow over a V-notch | Relate lab work to real-world fluid mechanics problems. | Assignment, Written, Quiz | CLO,CLO3 |
| 14,15 | Fluid Friction in a pipe | Assess understanding through detailed reports. | Class Participation | CLO2,CLO3 |
| 16,17 | Head Loss Due to Pipe Fittings | Hands on Practice | Viva, Quiz | CLO5,CLO1 |

Index

| Sr No | Date | Name of Experiment | Page No | Grade | Sign |
|-------|------|---|---------|-------|------|
| 1 | | Center of Pressure | | | |
| 2 | | Verification of Bernoulli's Theorem | | | |
| 3 | | Flow through Venturi meter | | | |
| 4 | | Flow through an Orifice | | | |
| 5 | | Flow through an External Cylindrical Mouthpiece | | | |
| 6 | | Flow over a sharp crested rectangular weir | | | |
| 7 | | Flow over a V-notch | | | |
| 8 | | Fluid Friction in a pipe | | | |
| 9 | | Head Loss Due to Pipe Fittings | | | |

Contents

| | |
|---|----|
| Experiment 1: Center of Pressure | 1 |
| Experiment 2: Verification of Bernoulli's Theorem..... | 8 |
| Experiment 3: Flow through Venturi meter | 14 |
| Experiment 4: Flow through an Orifice..... | 20 |
| Experiment 5: Flow through an External Cylindrical Mouthpiece | 28 |
| Experiment 6: Flow over a sharp crested rectangular weir | 33 |
| Experiment 7: Flow over a V-notch | 39 |
| Experiment 8: Fluid Friction in a pipe..... | 45 |
| Experiment 9: Head Loss Due to Pipe Fittings | 50 |

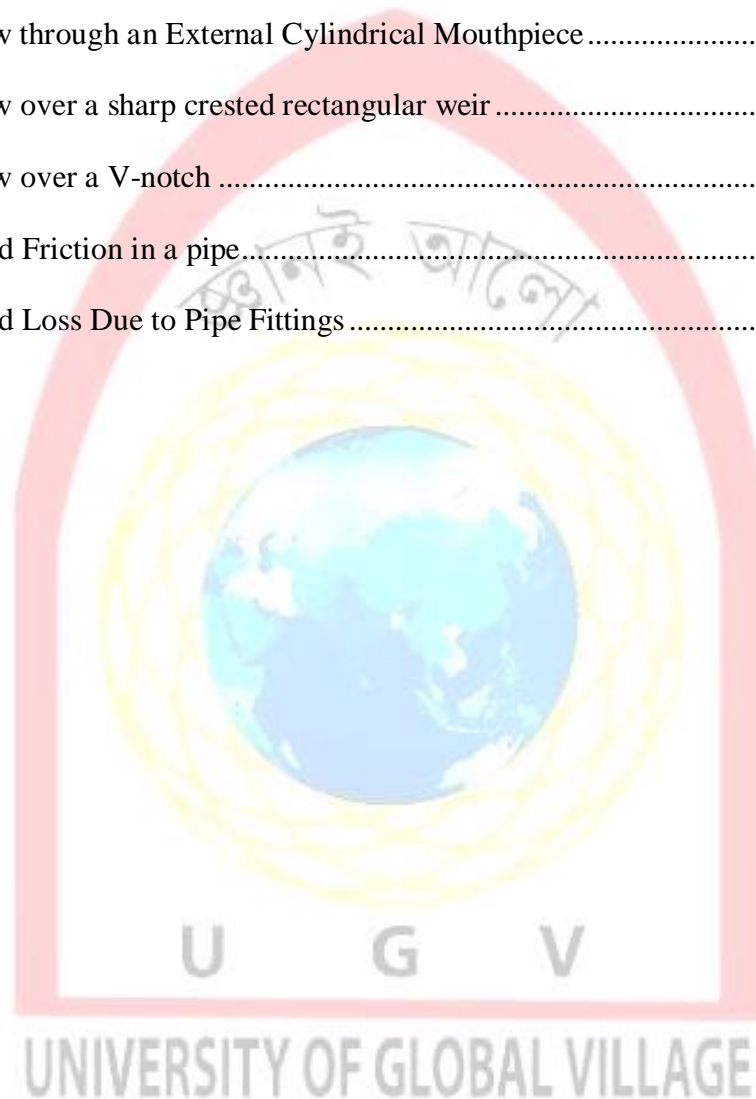

No. 1 Centre of Pressure

General

The centre of pressure is a point on the immersed surface at which the resultant of liquid pressure force acts. In case of horizontal area the pressure is uniform and the resultant pressure force passes through the centroid of the area, but for an inclined surface this point lies towards the deeper end for the surface, as the intensity of pressure increases with depth.

The objective of this experiment is to locate the centre of pressure of an immersed rectangular surface and to compare this position with that predicted by theory.

Practical Application

Hydrostatic force and its line of action is required for the design of many parts of hydraulic equipment. The location and magnitude of water pressure force acting on water-control structures, such as dams, levees, and gates, are very important to their structural design. In designing such hydraulic structure (e.g a dam) the overturning moment created by water pressure on the structure is required. In this case, $M_o = Fxd$, where F is the hydrostatic force on the dam and d is the distance of the centre of the pressure from bottom.



Figure 1-1: Practical application of centre of pressure

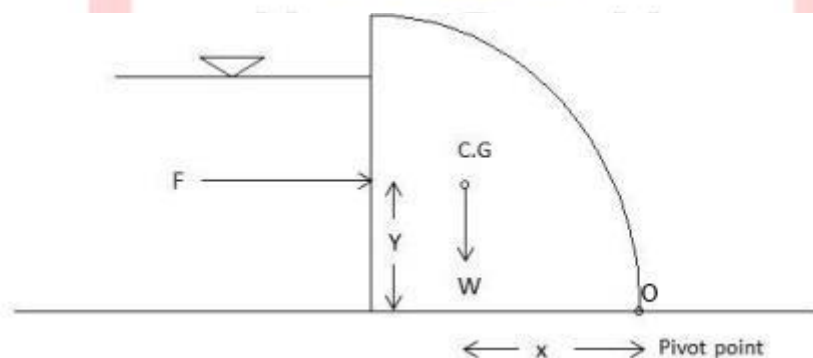

Figure 1-2: Location of the resultant force acting on a dam

Description of Apparatus

The apparatus is comprised basically of a rectangular transparent water tank, which supports a toroidal quadrant of rectangular section complete with an adjustable counter-balance and a water level measuring device.

The Clear Perspex (acrylic resin) rectangular water tank has a drain tap at one end and a knurled levelling screw at each corner of the base. Centrally disposed at the top edge of the two long sides, are mounted on the brass knife-edge supports, immersed within the tank and pivoted at its geometric centre of curvature on the knife-edge supports, is an accurate toroidal quadrant (ring segment). This is clamped and dowelled to an aluminum counter-balance arm which has a cast-iron main weight with a knurled head brass weight for fine adjustment at one end and a laboratory type Weight pan at the other end. Two spirit levels are mounted on the upper surface of the arm.

The Water level is accurately indicated by a point gauge which is at one of the tanks.

Theory

The magnitude of the total hydrostatic force F will be given by

$$F = \rho g \bar{y} A$$

Where ρ = Density of fluid

g = Acceleration due to gravity

\bar{y} = Depth to centroid of immersed surface

A = Area of immersed surface

This force will act through the centre of pressure C.P. at a distance y_p (Measured vertically)

from point O, where O is the intersection of the plane of the water surface and the plane of the rectangular surface.

Theoretical Determination of y_p :

Theory shows that

$$y_p = \bar{y} + \frac{I_{CG}}{A\bar{y}}$$

where

\bar{y} = distance from O to the centroid CG of the immersed surface.

I_{CG} = 2nd moment of area of the immersed surface about the horizontal axis through CG.

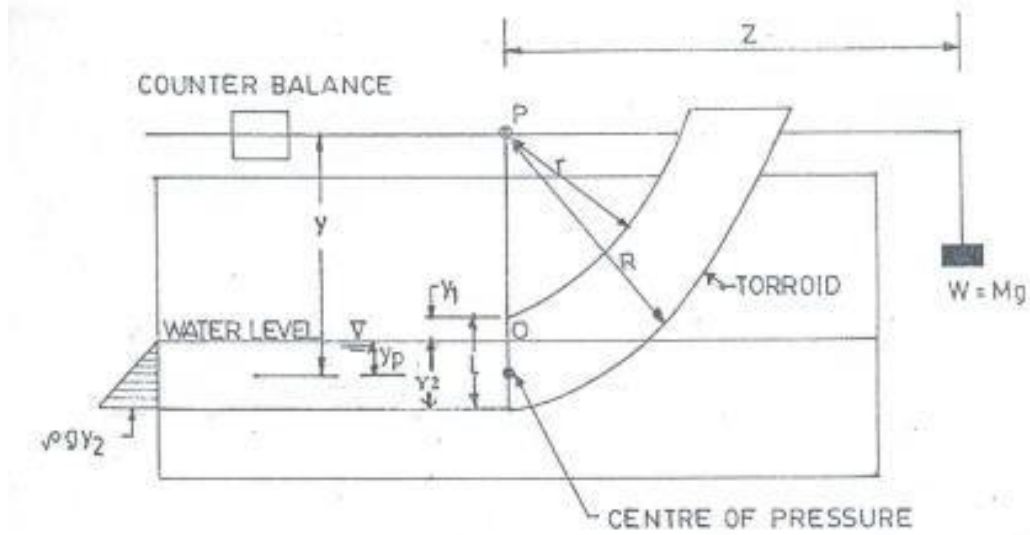

Figure 1-3: Partially submerged condition

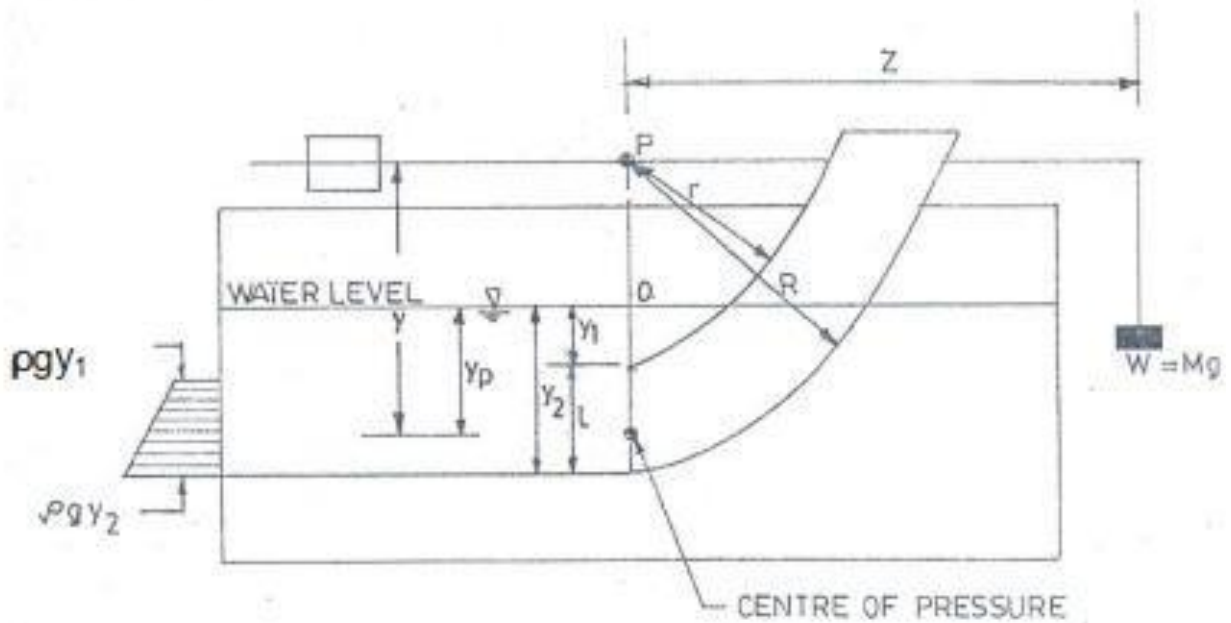

Figure 1-4: Fully submerged condition

Experimental Determination of y_p :

For equilibrium of the experimental apparatus, moments about the pivot P give

$$F y = W z$$

$$= m g \cdot z$$

Where

- y = Distance from pivot to centre of pressure
- m = Mass added to hanger
- z = Distance from pivot to hanger

Therefore

$$y = \frac{Mgz}{F}$$

But $y = y_p + r - y_1$ [fully submerged]

$y = y_p + r + y_1$ [partially submerged]

Therefore

$y_p = y - (r - y_1)$ [fully submerged]

$y_p = y - (r + y_1)$ [partially submerged]

Where

$r =$ Distance from pivot to top of rectangular surface

$y_1 =$ Distance from water surface to top of rectangular surface

In Fig

$y_2 =$ Distance from water surface to bottom of rectangular surface

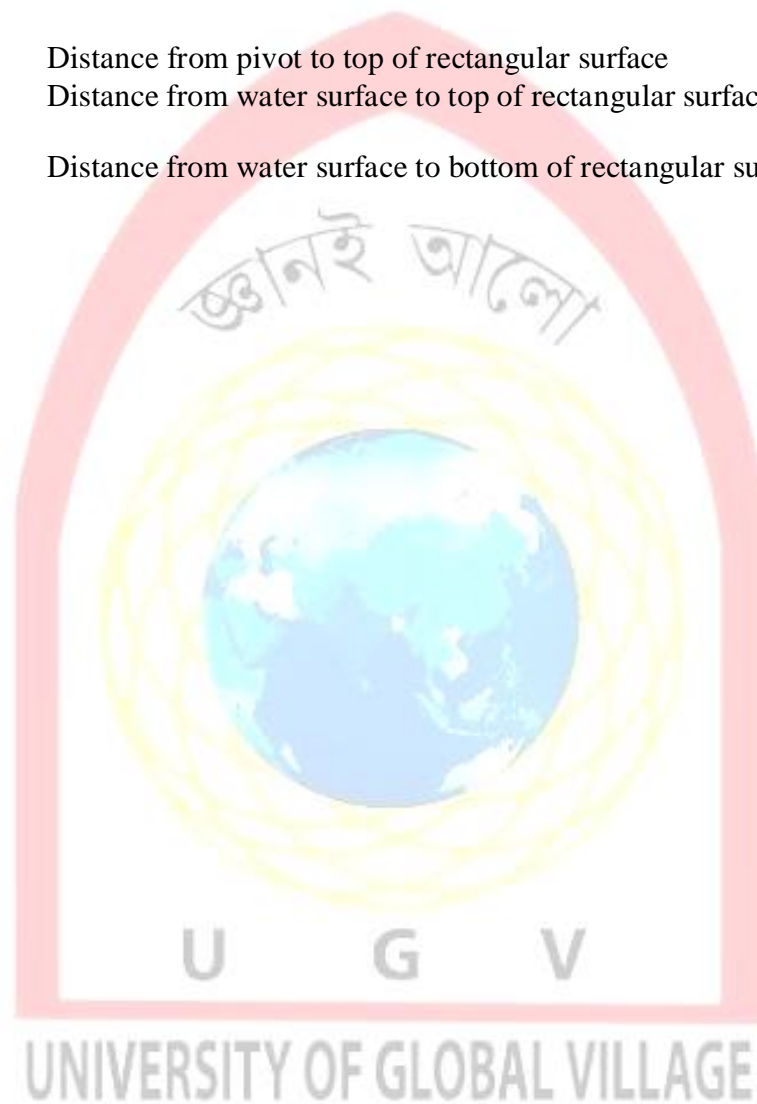

Procedure

1. The apparatus is placed in a splash tray and correctly leveled.
2. The length (l) and width (b) of the rectangular surface, the distance r from the pivot to the top of the surface, and the distance s from the hanger to the pivot were recorded.
3. The rectangular surface is positioned with the face vertical ($\theta=0$) and clamped.
4. The position of the moveable jockey weight is adjusted to give equilibrium, i.e. when the balance pin is removed there is no movement of the apparatus. The balance pin is replaced.
5. Water is added to the storage chamber. This created an out-of-balance clockwise moment in the apparatus. A mass M is added to the hanger and water is slowly removed from the chamber via drain hole such that the system is brought almost to equilibrium, but now clockwise moment is marginally greater. Water is slowly added to the storage chamber by a dropper until equilibrium is attained. At this condition the drain hole is closed and the balance pin again removed to check equilibrium.
6. The balance pin is replaced and the values of y_1 , y_2 and M were recorded.
7. The above procedure is repeated for various combinations of depth.

Objective

1. To determine the distance of center of pressure from the water surface both theoretically and practically.
2. To plot the mass on the pan (M) against y_2 in plain graph paper.

Practice Questions

1. Discuss why the centre of pressure is below the centre of gravity for a submerged plane or inclined surface.
2. What are the practical applications of the centre of pre



Experiment No.1
CENTRE OF PRESSURE
Experimental Data Sheet

Inner radius of curvature, r =.....

Outer radius of curvature, R =.....

Width of plane surface, b =.....

Height of Plane surface, l =.....

Distance from pivot to hanger, z =.....

| Group No. | y ₁ | y ₂ | \bar{y} | F | I _{CG} | $\frac{I_{cg}}{yA}$ | y _p theo. | M | y | y _p exp. | submerged condition Partially/fully | Comment |
|-----------|----------------|----------------|-----------|---|-----------------|---------------------|-------------------------|---|---|------------------------|--|---------|
| | | | | | | | | | | | | |

| | | | | |
|----------------|--|--|--|--|
| Group No. | | | | |
| Weight on pan | | | | |
| y ₂ | | | | |

UNIVERSITY OF GLOBAL VILLAGE

Signature of the teacher

Note: Suitable unit must be provided in the data sheet.

Experiment No. 2

VERIFICATION OF BERNOULLI'S THEOREM

General

Energy is the ability to do work. It manifests in various forms and can change from one form to another. These various forms of energy present in fluid flow are elevation, kinetic, pressure and internal energies. Daniel Bernoulli in the year 1738 stated that in a steady flow system of frictionless (or non-viscous) incompressible fluid, the sum of pressure, elevation and velocity heads remains constant at every section, provided no energy is added to or taken out by an external source.

Practical application

Bernoulli's equation can be applied in practice for designing of water flow system, designing of flow measuring devices such as venturimeter, nozzle, orifice meter and pitot tube, Furthermore, it can be applied to the problems of flow under a sluice gate, free liquid jet, radial flow and free vortex motion. It can also be applied to real incompressible fluids with good results in situations where frictional check is very small.

Description of apparatus

The unit is constructed as a single Perspex fabrication. It consists of two cylindrical reservoirs inter-connected by a Perspex Venturi of rectangular cross-section. The Venturi is provided with a number of Perspex piezometer tubes to indicate the static pressure at each cross-section. An engraved plastic backboard is fitted which is calibrated in British and Metric units. This board can be reversed and mounted on either side of the unit so that various laboratory configurations can be accommodated. The inlet vessel is provided with a dye injection system. Water is fed to the upstream tank through a radial diffuser from the laboratory main supply. For satisfactory results the mains water pressure must be nearly constant. After flowing through the venture, water is discharged through a flow-regulating device. The rate of flow through the unit may be detrimental either volumetrically or gravimetrically. The equipment for this purpose is excluded from the manufacturer's supply. The apparatus has been made so that the direction of flow through the venture can be reversed for demonstration purpose. To do this the positions of the dye injector and discharge fitting have to be interchanged.

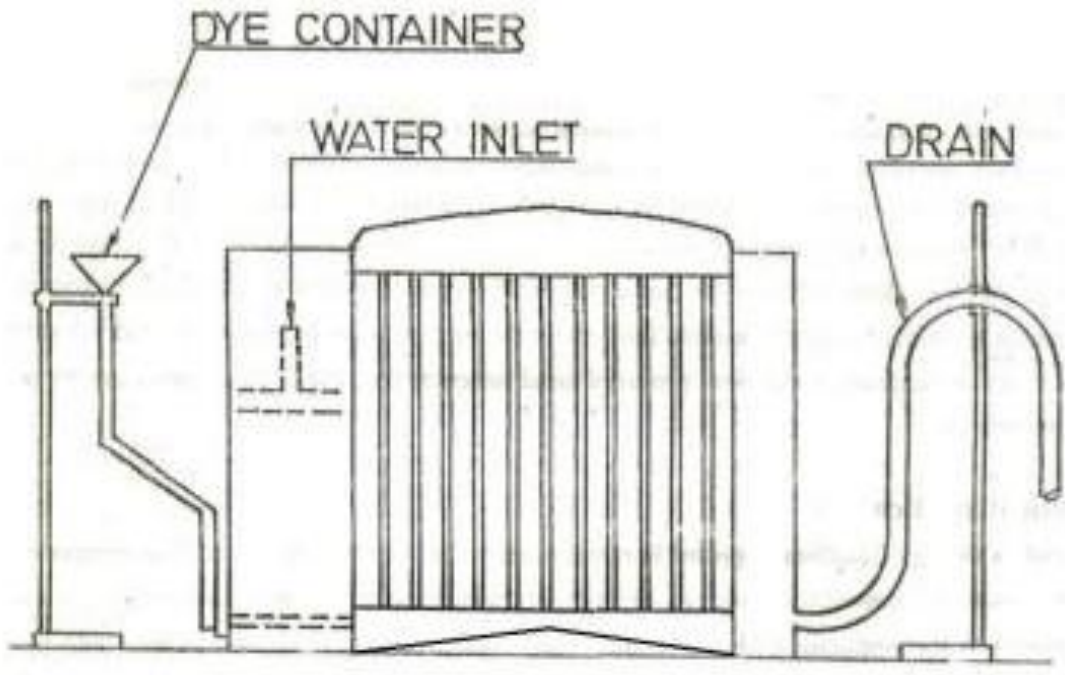

SKETCH OF APPARATUS

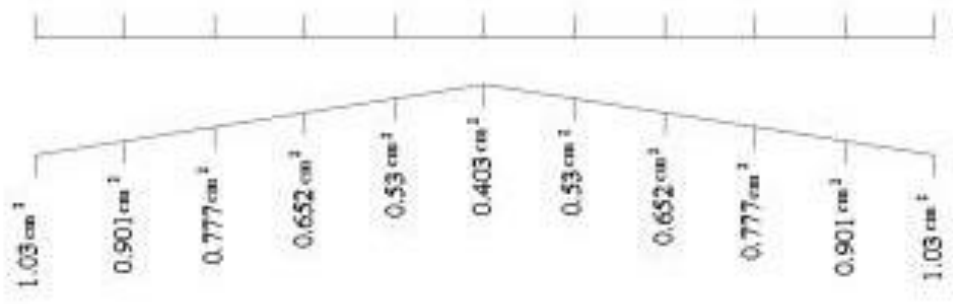

VENTURI DETAILS

Figure 2-1: Sketch of Apparatus and Venturi Details

Governing Equation

Assuming frictionless flow, Bernoulli's Theorem states that, for a horizontal conduit

$$\frac{P_1}{\gamma} + \frac{V_1^2}{2g} = \frac{P_2}{\gamma} + \frac{V_2^2}{2g} = \frac{P_3}{\gamma} + \frac{V_3^2}{2g} = \dots\dots\dots$$

- where, $P_1, P_2 =$ pressure of flowing fluid at sections 1 and 2
 $\gamma =$ unit weight of fluid
 $V_1, V_2 =$ mean velocity of flow at sections 1 and 2
 $g =$ acceleration due to gravity.

The equipment can be used to demonstrate the validity of this theory after an appropriate allowance has been made for friction losses.

For actual condition there must be some head loss in the direction of flow. So, if the head loss between section 1 and 2 is h_L Bernoulli's theorem is modified to

$$\frac{P_1}{\gamma} + \frac{V_1^2}{2g} = \frac{P_2}{\gamma} + \frac{V_2^2}{2g} + h_L$$

Procedure

1. The apparatus should be recurrently leveled by means of screws provided at the base.
2. Connect the water supply to the radial diffuser in the upstream tank.
3. Adjust the level of the discharge pipe by means of the stand and clamp provided to a convenient position.
4. Allow water to flow through the apparatus until all air has been expelled and steady flow conditions are achieved. This can be accomplished by varying the rate of inflow into the apparatus and adjusting the level of the discharge tube.
5. Readings may then be taken from the piezometer tubes and the flow through the apparatus measured.
6. A series of readings can be taken for various through flows.

Objective

1. To plot the static head, velocity head and total head against the length of the passage in one plain graph paper.
2. To plot the total head loss h_L , against the inlet kinematics head, $V^2/2g$, for different in-flow conditions in plain graph paper.

Practice Question

1. What are the assumptions underlying the Bernoulli equation?
2. Do you need any modification (s) of Eq. (1) when (a) the frictional head loss is to be considered, and (b) the conduit is not horizontal?
3. What is the difference between energy line and energy grade line?



Experiment No. 2

EXPERIMENTAL VERIFICATION OF BERNOULLI'S THEOREM

Experimental Data Sheet

Cross-sectional area of the measuring tank= _____

Initial point gage reading = _____

Final point gage reading = _____

Collection time = _____

Volume of water = _____

Discharge Q = _____

| Piezometer tube no. | 1 | 2 | 3 | 4 | 5 | 6 | 7 | 8 | 9 | 10 | 11 |
|-------------------------|---|---|---|---|---|---|---|---|---|----|----|
| A | | | | | | | | | | | |
| $V=Q/A$ | | | | | | | | | | | |
| $V^2/(2g)$ | | | | | | | | | | | |
| P/γ | | | | | | | | | | | |
| $H=P/\gamma + V^2/(2g)$ | | | | | | | | | | | |

| Gr. No. | 1 | 2 | 3 | 4 | 5 |
|--------------|---|---|---|---|---|
| $V_1^2 / 2g$ | | | | | |
| h_L | | | | | |

Note: Suitable unit must be provided in the data sheet.

Signature of the teacher

Experiment No. 3

FLOW THROUGH VENTURIMETER

General

The converging tube is an efficient device for converting pressure head to velocity head, while the diverging tube converts velocity head to pressure head. The two may be combined to form venturi tube. As there is a definite relation between the pressure difference and the rate of flow. The tube may be made to serve as metering device.

Venturi meter consists of a tube with a constricted throat that produces an increased velocity accompanied by a reduction in pressure followed by a gradual diverging portion in which velocity is transformed back into pressure with slight frictional loss.

Practical application

The venturimeter is used for measuring the flow rate through a pipe for both compressible and incompressible fluids.

The venturimeter provides an accurate means for measuring flow in pipelines. Aside from the installation cost, the only disadvantage of the venturimeter is that it introduces a permanent frictional resistance in the pipelines.

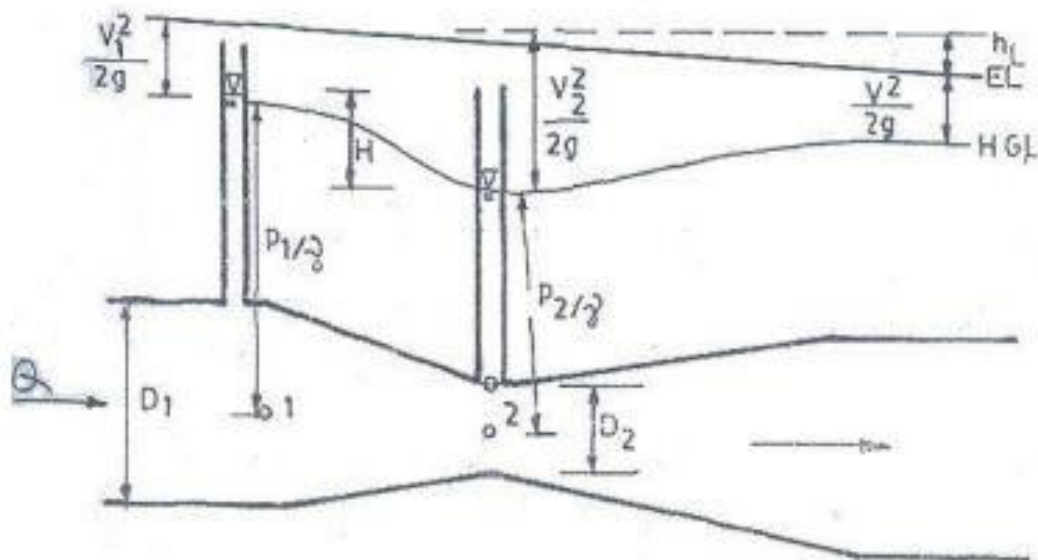

Figure 3-1: Flow through a venturi meter

Theory

Consider the Venturimeter shown in Figure 1. Applying the Bernoulli's equation between Point 1 at the inlet and point 2 at the throat, following relation can be obtained.

$$\frac{P_1}{\gamma} + \frac{V_1^2}{2g} = \frac{P_2}{\gamma} + \frac{V_2^2}{2g} \quad \dots(1)$$

Where P_1 and V_1 are the pressure and velocity at point 1, P_2 and V_2 are the corresponding quantities at point 2, γ is the specific weight of the fluid and g is the acceleration due to gravity from continuity equation, we have.

$$A_1 V_1 = A_2 V_2 \quad \dots(2)$$

Where, A_1 and A_2 are the cross-sectional areas of the inlet and throat respectively since

$$A_1 = \frac{\pi}{4} D_1^2, A_2 = \frac{\pi}{4} D_2^2$$

From Equations (1) and (2), we have

$$V_1 = \sqrt{\frac{2g}{\left(\frac{D_1}{D_2}\right)^4 - 1}} \frac{(P_1 - P_2)}{\gamma} = K_1 H^{1/2} \quad \dots(3)$$

Where,

$$K_1 = \sqrt{\frac{2g}{\left(\frac{D_1}{D_2}\right)^4 - 1}}$$

And, $H = \frac{(P_1 - P_2)}{\gamma}$

The head H is indicated by the piezometer tubes connected to the inlet and throat.

The theoretical discharge, Q_t is given by

$$Q_t = A_1 V_1 = K_1 A_1 H^{1/2} \quad \dots(4)$$

Where,

$$K = K_1 A_1 \quad \dots(5)$$

Coefficient of discharge

Theoretical discharge is calculated from theoretical formula neglecting losses, friction losses. For this reason, a coefficient is introduced, named coefficient of discharge (C_d) which is the ratio of actual discharge to theoretical discharge.

Now, if C_d is the coefficient of discharge (also known as the meter coefficient) and Q_a is the actual discharge then,

$$\begin{aligned}C_d &= \frac{Q_a}{Q_t} \\Q_a &= C_d Q_t \\&= C_d K H^{1/2} \\&= C H^n \quad \dots (6)\end{aligned}$$

The value of C_d may be assumed to be about 0.99 for large meter and about 0.97 or 0.98 for small ones provided the flow is such as to give reasonably high Reynolds number.

Calibration

One of the objectives of the experiment is to find the values of C and n for a particular meter so that the relation can be used to measure actual discharge only by measuring H . For five sets of actual discharge and H data we plot Q_a vs. H in log-log paper and draw a best-fit straight line.

The equation of straight line is as follows:

$$\log Q_a = \log C H^n$$

$$\log Q_a = \log C + n \log H$$

Now from the plotting, take two points on the straight line say (H_1, Q_{a1}) and (H_2, Q_{a2})

From the equation (3), one can get

$$\begin{aligned}\log Q_{a1} &= \log C + n \log H_1 \\ \log Q_{a2} &= \log C + n \log H_2\end{aligned}$$

$$\text{Solving, } n = \frac{\log \frac{Q_{a1}}{Q_{a2}}}{\log \frac{H_1}{H_2}}$$

$$C = \text{antilog} [\text{anti log } Q_{a1} - n \log H_1]$$

So the calibration equation is $Q_a = C H^n$

$$\text{Now } C = C_d K$$

$$C_d = C/K$$

Now from the calibration equation, calculate the actual discharge for different H and plot on a plain graph paper. In practice use the plot to find actual discharge for any H . Thus, the venturi meter is calibrated.

Objective

1. To find C_d for the Venturimeter
2. To plot Q_a against H in log-log paper and to find (i) exponent of H and(ii) C_d -
3. To calibrate the Venturimeter.

Practice Questions

1. Why is the diverging angle smaller than the converging angle for a venturimeter?
2. How can the accuracy of venturimeter be increased in use?
3. On what factors does the meter co-efficient depend?

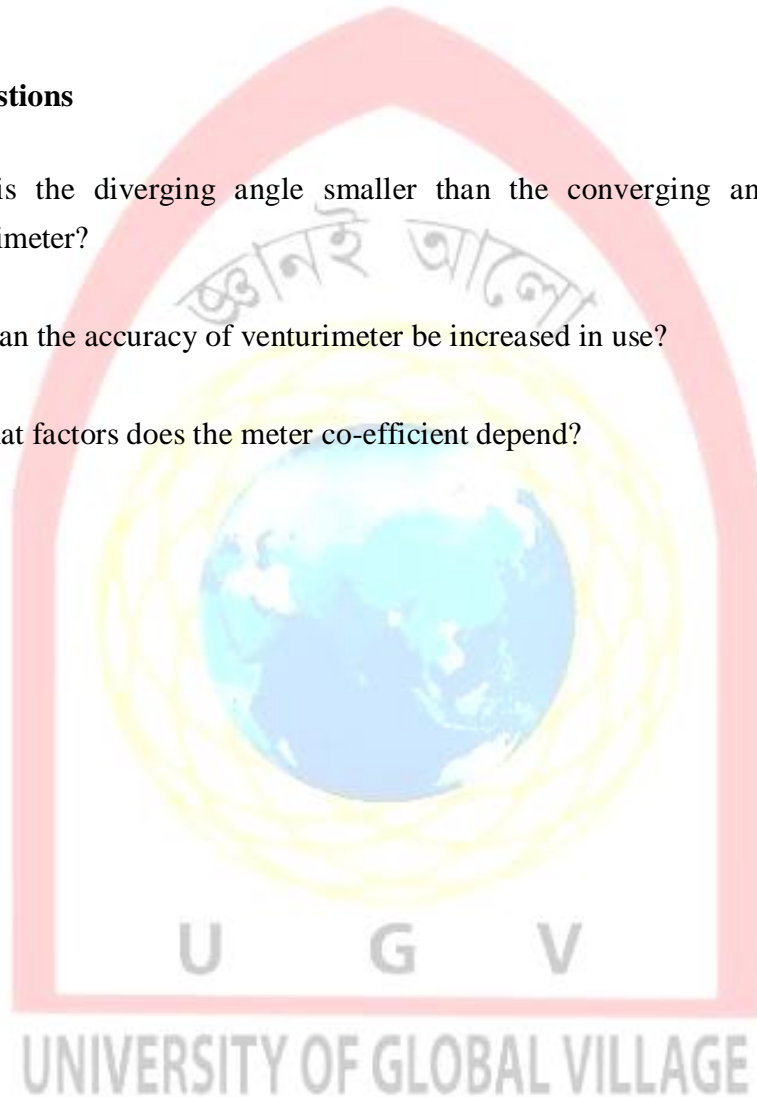

Experiment No.3
FLOW THROUGH A VENTURIMETER
 Experimental Data and Calculation Sheet

Cross sectional area of the measuring tank, $A =$ _____

Pipe diameter, $D_1 =$ _____ Area of the pipe, $A_1 =$ _____

Throat diameter $D_2 =$ _____ Area of the throat, $A_2 =$ _____

Temperature of water, $t =$ _____ Kinematic viscosity of water $\nu =$ _____

Initial point gage reading = _____ Final point gage reading = _____

| No. of obs. | Volume of water v | Time T | Actual Discharge Q_a | Piezometer reading | | | k_1 | k | Theoretical discharge Q_t | $C_d = \frac{Q_a}{Q_t}$ | $V_2 = \frac{Q_a}{A_2}$ | Reynolds number R_e |
|-------------|---------------------|----------|------------------------|--------------------|-------------|----------|-------|-----|-----------------------------|-------------------------|-------------------------|-----------------------|
| | | | | Left h_1 | Right h_2 | Diff H | | | | | | |
| | | | | | | | | | | | | |
| | | | | | | | | | | | | |
| | | | | | | | | | | | | |
| | | | | | | | | | | | | |

| | | | | | |
|--------------------------|--|--|--|--|--|
| Group No. | | | | | |
| Actual discharge Q_a | | | | | |
| Head difference H | | | | | |
| Coefficient of discharge | | | | | |
| Reynolds number | | | | | |

Note: Suitable unit must be provided in the data sheet.

Signature of the Teacher

Experiment No. 4 FLOW THROUGH AN ORIFICE

General

An orifice is an opening in the wall of a tank or in a plate normal to the axis of a pipe, the plate being either at the end of pipe or in some intermediate location. An orifice is characterized by the fact that the thickness of the wall or plate is very small relative to the size of the opening. For a standard orifice there is only a line contact with fluid.

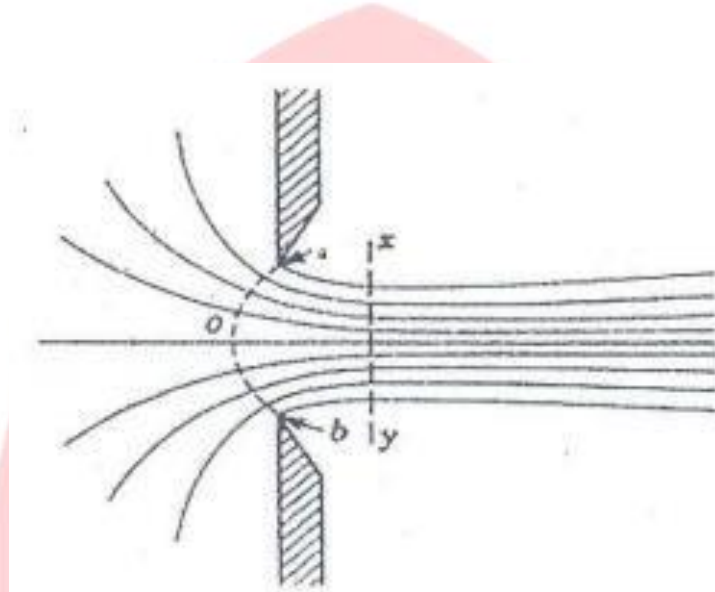

Figure 4-1: Jet Contraction

Where the streamlines converge in approaching an orifice, they continue to converge beyond the upstream section of the orifice until they reach the section xy where they become parallel. Commonly this section is about $0.5D_o$ from the upstream edge of the opening, where D_o is diameter of the orifice. The section xy is then a section of minimum area and is called the vena contracta. Beyond the vena contracta the streamlines commonly diverge because of frictional effects.

Practical application

The usual purpose of an orifice is the measurement or control of flow from a reservoir. The orifice is frequently encountered in engineering practice operating under a static head where it is usually not used for metering but rather as a special feature in a hydraulic design. Another problem of orifice flow, which frequently arises in engineering practice, is that of discharge from an orifice under falling head, a problem of unsteady flow.

Theory:

Coefficient of contraction:

The ratio of the area of a jet at the vena contracta to the area of the orifice is called the coefficient of contraction.

Coefficient of velocity:

The velocity that would be attained in the jet if the friction did not exist may be termed the theoretical velocity. The ratio of actual to the theoretical velocity is called coefficient of velocity.

Coefficient of discharge:

The ratio of the actual rate of discharge Q_a to the theoretical rate of discharge Q_t (the flow that would occur if there were no friction and no contraction) is defined as the coefficient of discharge.

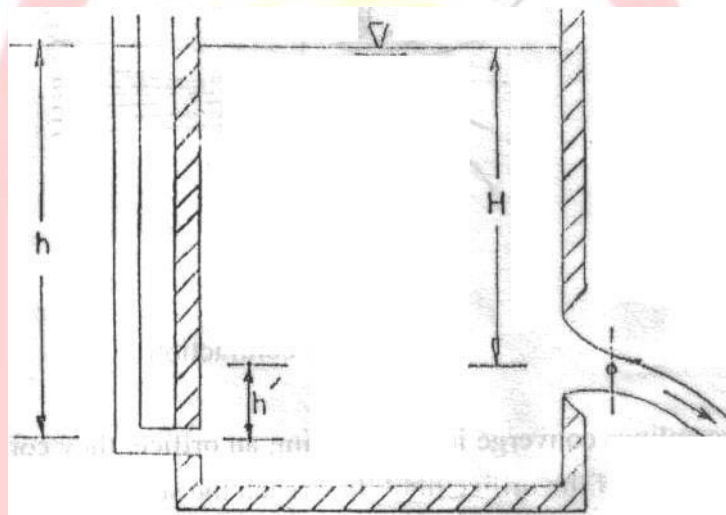

Figure 4-2: Flow Through an orifice

Consider a small orifice having a cross-sectional area A and discharging water under a constant head H as shown in the above figure. Applying Bernoulli's theorem between the water surface and at point of vena contracta. One can obtain

$$V_t = \sqrt{2gH}$$

where g is the acceleration due to gravity.

So theoretical discharge Q_t is given by

$$Q_t = A\sqrt{2gH}$$

Let Q_a be the actual discharge, then the coefficient of discharge, C_d is given by

$$C_d = \frac{Q_a}{Q_t}$$

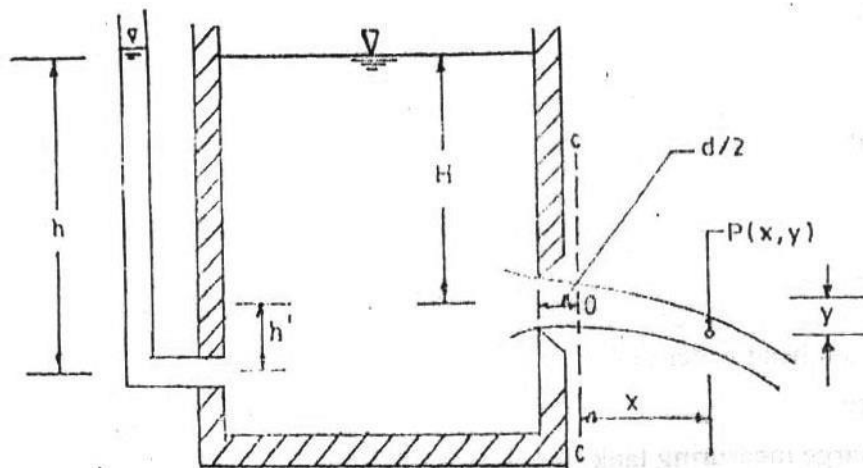

Figure 4-3: Co-efficient of Velocity by Co-ordinate Method

Let H be the total head causing flow and section-c-c conditions the vena contracta as shown in the figure. The jet of water has a horizontal velocity but is acted upon by gravity with a downward acceleration of g . Let us consider a particle of water in the jet at P and let the time taken for this to move particle from O to P be t .

Let x and y be the horizontal and vertical co-ordinates of P from O , respectively. Then,

$$x = V_a t$$

and

$$y = \frac{1}{2} g t^2$$

Equating the value of t^2 from these two equations, one obtains

$$\frac{x^2}{V_a^2} = \frac{2y}{g}$$

$$V_a = \sqrt{\frac{g x^2}{2y}}$$

But, the theoretical velocity, $V_t = \sqrt{2gH}$

Hence, the coefficient of velocity, C_v is given by

$$C_v = \frac{v_a}{v_t} = \sqrt{\frac{x^2}{4yH}}$$

And the head loss is given by

$$H_t = (1 - C_v^2)H$$

$$C_v = \frac{v_a}{v_t} = \frac{v_a}{\sqrt{2gH}}$$

Coefficient of contraction, C_c is defined as the area of jet at vena contracta to the area of orifice, thus,

$$C_c = \frac{A_a}{A}$$

It follows that

$$C_d = C_c \times C_v$$

Apparatus

1. Constant head water tank
2. Orifice
3. Discharge measuring tank
4. Stop watch
5. Point gauge

Procedure

Co-efficient of Velocity by Co-ordinate Method

1. Measure the diameter of the orifice.
2. Supply water to the tank.
3. When the head at the tank (measured by a manometer attached to the tank) is steady record the reading of the manometer.
4. Measure the x and y co-ordinate of the jet from the vena contracta.
5. Measure the flow rate.
6. Repeat the procedure for different combinations of discharge.

Orifice Plate Meter

1. Start the pump and establish a water flow through the test section. Raise the swivel tube of the outlet tank so that it is close to the vertical. Adjust the vent regulating valve to provide a small overflow from the inlet tank and overflow pipe. Ensure that any air bubbles are bled from the manometer.
2. Set up a series a of flow conditions with differential heads. At each condition carefully measure the flow rate using the volumetric tank and a stop watch. Record the differential head across the orifice plate twice, i.e. for the D and D/2 tappings.
3. Determine the theoretical discharge, actual discharge and the coefficient of discharge.
4. Plot Actual discharge vs. pressure head difference on log-log graph paper.
5. Develop the Calibration equation and draw the calibration graph.

Objective

1. To find the value of C_d for the orifice.
2. To plot Q_a vs. H in log-log paper and to find the value of (a) the exponent of H and (b) C_d .
3. To find C_v for the orifice.
4. To find the head loss, H_L .
5. To plot V_a vs. H in log-log paper and to find (a) C_v and (b) the exponent of H .

Practice Questions

1. What are the coefficient of velocity, coefficient of contraction and coefficient of discharge for an orifice? On what factors do these coefficients depend? What are average values of these coefficients for a sharp-crested orifice?
2. What is a submerged orifice? What are the average values of the coefficient of velocity, coefficient of contraction and coefficient of discharge for a submerged orifice?
3. Why is the actual discharge through an orifice less than the theoretical discharge?
4. Define vena contracta. Why does it form?
5. Will the value of C_v be different for sharp-edged and rounded orifices? Why?



Experiment No. 4
 FLOW THROUGH AN ORIFICE
 Observation and Calculation Sheet

Area of the orifice =

Area of the pipe =

| Quantity of Water Collected Q litre | Time to Collect Water, t sec | Volumetric Flow Rate, Q litres/min | D Tappings Upstream H ₁ (m) | D/2 Tappings Downstream H ₂ (m) | D & D/2 Tappings Diff. Head H (m) | C _d |
|--|---------------------------------|---------------------------------------|---|---|--------------------------------------|----------------|
| | | | | | | |
| | | | | | | |
| | | | | | | |
| | | | | | | |
| | | | | | | |
| | | | | | | |



 Signature of the Teacher

Note: Suitable unit must be provided in the data sheet.

| No. Of Obs. | Horizontal Coordinate x | vertical Coordinate y | Actual velocity V_a | Coeff. of velocity C_v | Head loss H_L |
|-------------|-------------------------|-----------------------|-----------------------|--------------------------|-----------------|
| | | | | | |

| | | | | | |
|-----------------------------|--|--|--|--|--|
| No. of observation | | | | | |
| Actual discharge, Q_a | | | | | |
| Theoretical Discharge Q_t | | | | | |
| Actual Velocity V_a | | | | | |
| Theoretical velocity V_t | | | | | |
| Actual head H | | | | | |

Signature of the Teacher

Note: Suitable unit must be provided in the data sheet.

UNIVERSITY OF GLOBAL VILLAGE

Experiment No. 5

FLOW THROUGH AN EXTERNAL CYLINDRICAL MOUTHPIECE

General

If a small tube is attached to an orifice, it is called mouthpiece. The standard length of a mouthpiece is $3d$, where d is the diameter of the orifice. If the length is less than $3d$, jet after passing the vena contracta does not occupy the tube fully and thus acts as orifice. If the length is greater than $3d$, it acts as pipe.

The effect of adding a mouthpiece to an orifice is to increase the discharge. The pressure at vena contracta is less than atmospheric, so a mouthpiece decreases the pressure at vena contracta and increases the effective head causing the flow, hence, discharge is increased. The pressure at outlet is atmospheric but as the velocity of the vena contracta is greater than the velocity at outlet, the pressure at vena contracta will be less than atmospheric.

Practical application

Flow through an orifice can not represent the flow through a pipe properly. Also in orifice, coefficient of discharge is only 0.62. So to increase discharge from a reservoir and represent the flow through pipe mouthpiece is used.

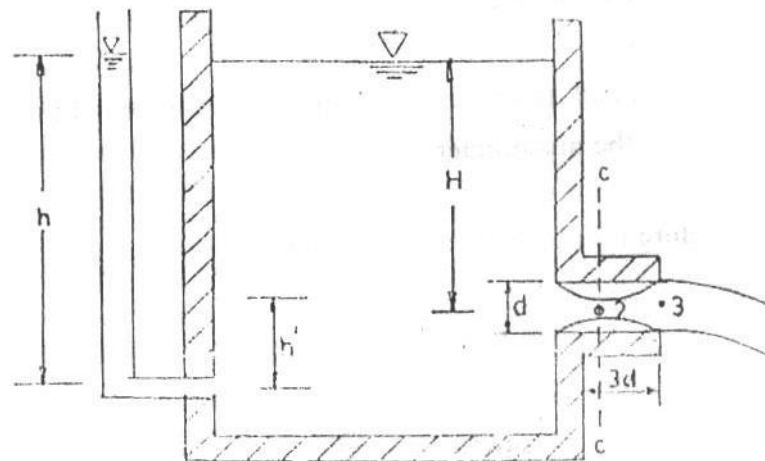

Figure 5-1: Flow Through an External Cylindrical Mouthpiece

Theory

Consider an external cylindrical mouthpiece of area A discharging water under a constant head H as shown in the figure. Applying Bernoulli's equation at point 1 and 3,

$$H = \frac{V^2}{2g}$$

$$V = \sqrt{2gH}$$

Then the theoretical discharge, Q_t , is given by

$$Q_t = A\sqrt{2gH}$$

where A is the area of the mouthpiece. Let Q_a be the actual discharge then the coefficient of discharge C_d is given by,

$$C_d = \frac{Q_a}{Q_t}$$

Apparatus

1. Constant head water tank
2. Mouth piece
3. Discharge measuring tank
4. Stop watch
5. Point gauge

Procedure

1. Measure the diameter of the orifice.
2. Attach the mouth piece to the orifice of the constant head water tank.
3. Supply water to the tank.
4. When the head at the tank (measured by a manometer attached to the tank) is steady, record the reading of the manometer.
5. Measure the flow rate.
6. Repeat the procedure for different combinations of discharge.

Objective

1. To find C_d for the mouthpiece.
2. To plot Q_a vs. H in log-log paper, and to find (a) C_d and (b) the exponent of H

Practice Questions

1. Explain why the discharge through an orifice is increased by fitting a standard short tube to it.
2. What will happen to the coefficient of discharge if the tube is shorter than the standard length or the head causing the flow is relatively high?
3. What is the effect of rounding the entrance of the mouthpiece?
4. What is a submerged tube? Does the coefficient of the tube change due to submergence?



Experiment 5
FLOW THROUGH AN EXTERNAL CYLINDRICAL MOUTHPIECE
 Calculation Sheet

Diameter of the mouthpiece, $D =$ _____
 Area of the mouthpiece, $A =$ _____
 Cross-sectional area of the measuring tank = _____
 Head correction, $h' =$ _____
 Initial point gauge reading = _____
 Final point gauge reading = _____
 Difference in gauge reading = _____

Observed head, $h' =$ _____

| No. of Obs | Actual head $H = h - h'$ | Volume of water | Collection time T | Actual Discharge Q_a | Theoretical Discharge Q_t | Co-efficient. of Discharge C_d |
|------------|--------------------------|-----------------|---------------------|------------------------|-----------------------------|----------------------------------|
| | | | | | | |

| | | | | | | |
|-------------------------|--|--|--|--|--|--|
| No of observations | | | | | | |
| Actual discharge, Q_a | | | | | | |
| Actual Head H | | | | | | |



 Signature of the Teacher

Note: Suitable unit must be provided in the data sheet.

Experiment No. 6 FLOW OVER A SHARP-CRESTED RECTANGULAR WEIR

General

A weir is an overflow structure built across an open channel for the purpose of measuring the flow. Weirs are commonly used to measure flow of water, but their use in measurement of other liquids is increasing.

Classified with reference to the shape of the opening through which the liquid flows, weirs may be rectangular, triangular, trapezoidal, circular, parabolic or of any other regular form. The first three forms are most commonly used for measurement of water. Classified with reference to the form of crest (the edge or the top surface with which liquid comes in contact) weirs may be sharp-crested or broad-crested.

The sharp-crested rectangular weir has a sharp upstream edge so formed that the liquid in passing touches only a line.

The overfalling stream is termed as 'nappe'. The nappe of a sharp crested weir as shown in fig is contracted at its underside by the action of the vertical components of the velocity just upstream from the weir. This is called crest contraction. If the sides of the opening also have sharp upstream edge so that the nappe is contracted in width, the weir is said to have end contractions and is usually called a contracted weir.

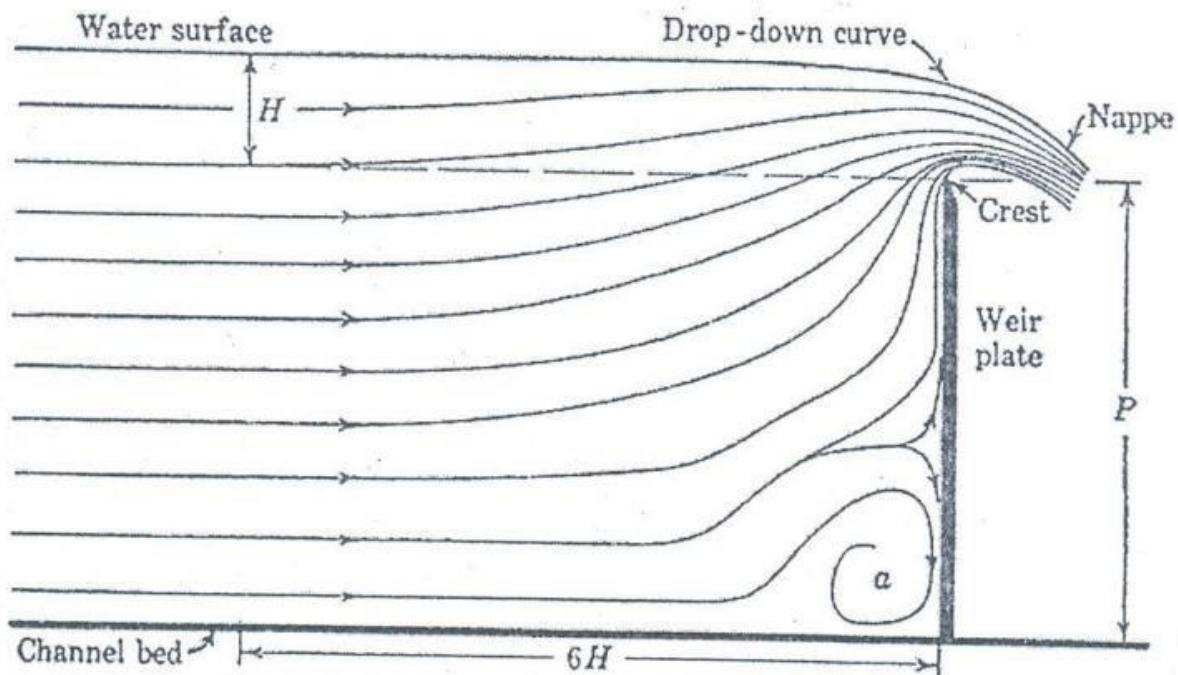

Figure 6-1: Path lines of flow over rectangular sharp crested weir

Practical application

Shallow rivers are often navigable by building dams across the river at certain sections over which the water may flow. During a drought little or no water will flow past the dam, but after heavy rains the water flows over the dam, thus converting it into a weir. Also flow through canal is measured by weirs.

Theory

The relationship between discharge and head over the weir can be developed by making the following assumptions as to the flow behavior:

1. Upstream of the weir, the flow is uniform and the pressure varies with depth according to the hydrostatic equation $P = \gamma h$.
2. The free surface remains horizontal as far as the plane of the weir, and all particles passing over the weir move horizontally. (In fact, the free surface drops as it approaches the weir).
3. The pressure throughout the sheet of liquid or nappe, which passes over the crest of the weir, is atmospheric.
4. The effects of viscosity and surface tension are negligible.
5. The upstream approach velocity head is neglected.

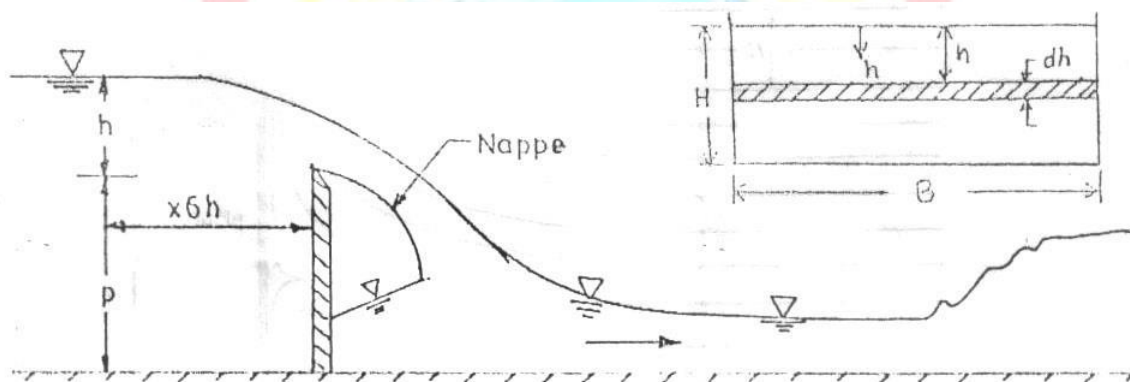

Figure 6-2: Flow Over a Sharp-Crested weir

UNIVERSITY OF GLOBAL VILLAGE

Now consider the sharp-crested weir in the figure. Let H be the working head and B is the length of the weir.

Let us consider a small horizontal strip of thickness dh under a head h. The strip can be considered as an orifice.

Therefore, the theoretical discharge through the strip

$$dQ_t = \text{area of the strip} \times \text{velocity} \quad (1)$$

$$= (Bdh) \sqrt{2gh} \quad \dots(2)$$

Integrating between the limits 0 and H, the total theoretical discharge over the weir is given by

$$Q_t = \frac{2}{3} \sqrt{2g} BH^{3/2} \dots\dots(3)$$

Let Q_a be the actual discharge. Then the co-efficient of discharge, C_d , is given by

$$C_d = \frac{Q_a}{Q_t} \dots\dots(4)$$

Therefore,

$$Q_a = \frac{2}{3} C_d \sqrt{2g} BH^{3/2} \dots\dots\dots(5)$$

$$= KC_d H^{3/2} \dots\dots\dots(6)$$

where,

$$K = \frac{2}{3} \sqrt{2g} B \dots\dots\dots(7)$$

For a contracted weir, B in equation (5) should be replaced by effective length (B') which is given by

$$B' = B - 0.1nH$$

Where n is the number of end contraction.

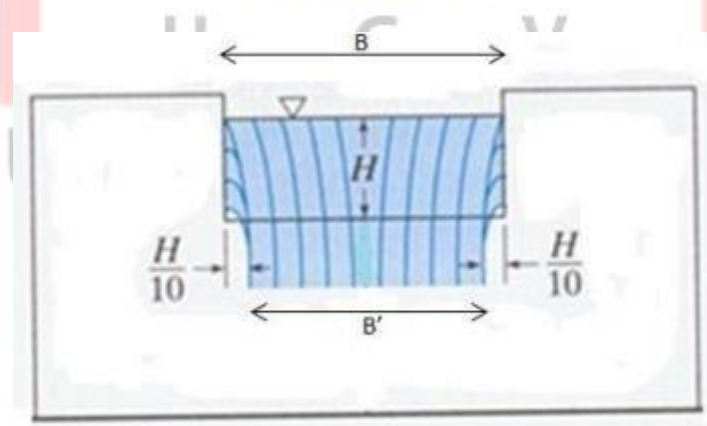

Figure 6-3: Weir with end contractions

Apparatus

1. A constant steady water supply with a means of varying the flow rate.
2. An approach channel
3. A rectangular weir plate
4. A flow rate measuring facility
5. A point gauge for measuring H

Procedure

1. Measure the height and length of the weir. Position the weir plate at end side of the approach channel, in a vertical plane, with sharp edge on the upstream side.
2. Allow water to the channel so that water flows over the weir and wait until water surface comes to a steady condition.
3. Ventilate the nappe with a pipe.
4. Set an elevation of zero of the point gauge with reference to the bottom of the channel.
5. Check *again* whether the nappe is ventilated or not. If not, ventilate it.
6. Carefully set the point gauge on the water surface 4 to 6ft upstream of the weir and take the gauge reading. The water surface may be slightly fluctuating.
7. Take the discharge reading from the flow meter.

Objective

1. Observation of the nappe for ventilated and non-ventilated conditions.
2. To find C_d for the weir
3. To plot Q_a vs. H in a plain graph paper.
4. To plot Q_a vs. H in a log-log graph paper and to find (1) the exponent of H and (2) C_d

Practice Questions

1. What are the assumptions made in deriving this equation? What is the extent of their validity?
2. Why the pressure distribution over the weir-crest is less than hydrostatic?
3. Why it is necessary to ventilate the space below the nappe?
4. Discuss the effects of lateral contraction, in case of contracted weir, on the flow over the weir
5. A rectangular sharp crested weir 3.0 ft high extends across a rectangular channel, which is 8.0 ft wide. When the head is 1.20 ft, find the rate of discharge by neglecting the velocity of approach.

Experiment No. 6
FLOW OVER A SHARP-CRESTED WEIR
 Experimental Data Sheet

Width of the weir, B = _____
 Height of the weir, P = _____
 Elevation of bed level = _____
 Final water level = _____
 Difference in water level, H = _____

| No of Obs. | Actual discharge Q_a | Ventilated Condition | | Co-efficient. of discharge C_d |
|------------|------------------------|----------------------|-----------------------------|----------------------------------|
| | | Head H | Theoretical discharge Q_t | |
| | | | | |
| | | | | |
| | | | | |
| | | | | |
| | | | | |

 Signature of the Teacher

Note: Suitable unit must be provided in the data sheet.



Experiment. No. 7
FLOW OVER A V-NOTCH

General

The most common types of sharp-crested weir are the rectangular weir and the triangular weirs. The triangular weir or V-notch is preferable to the rectangular weir for the measurement of wide range of flow.

Practical application

When small quantity of flow need to be measured the V-notch weir is preferable. when small discharges are involved, because the triangular cross-section of the flow 'nappe' leads to a relatively greater variation in head. V-notch weir has the advantage that it can function for a very small flows and also measure reasonably larger flows as well.

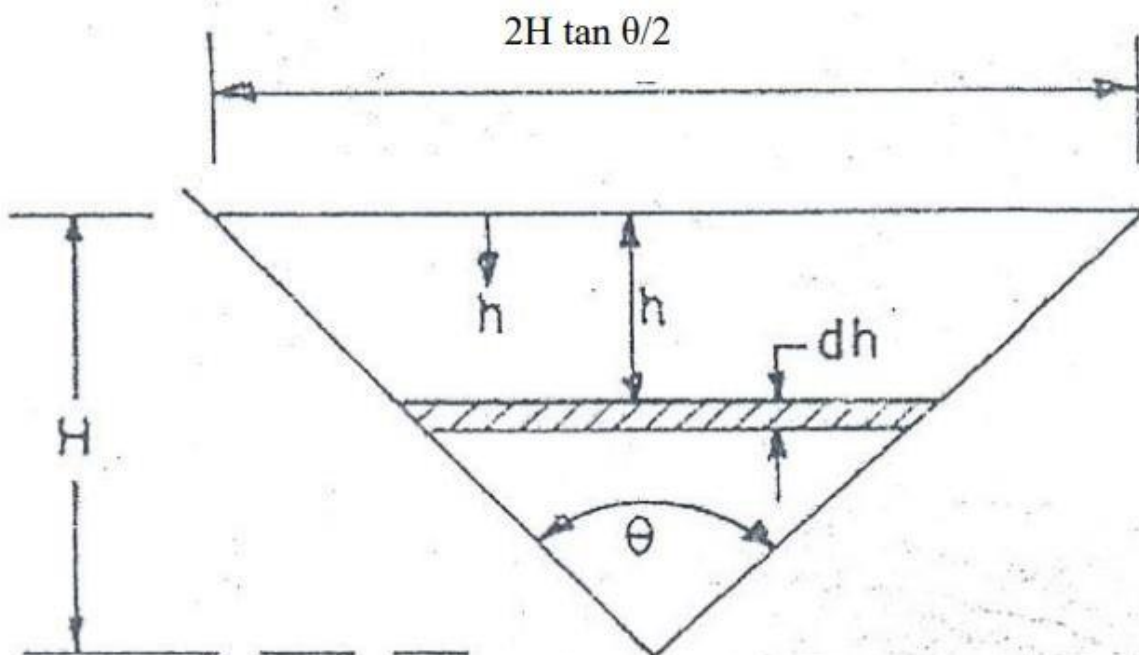

Figure 7-1: Flow over a V-Notch

Theory

Consider the V-notch shown in the figure. Let H be the height of water surface and θ be the angle of notch. Then width of the notch at the water surface.

$$L = 2H \tan \frac{\theta}{2} \quad \dots\dots(1)$$

Consider a horizontal strip of the notch of thickness dh under a head h . Then, width of the strip, $W = 2(H - h) \tan \frac{\theta}{2}$ (2)

Hence, the theoretical discharge through the strip

$$dQ_t = \text{area of the strip} \times \text{velocity} = 2(H-h) \tan \frac{\theta}{2} dh \sqrt{2gh} \quad \dots\dots(3)$$

Integrating between the limits 0 and H and simplifying, the total theoretical discharge over the notch is given by

$$Q_t = \frac{8}{15} \sqrt{2g} \tan \frac{\theta}{2} H^{5/2} \quad \dots\dots(4)$$

$$= KH^{5/2} \quad \dots\dots(5)$$

Where,

$$K = \frac{8}{15} \sqrt{2g} \tan \frac{\theta}{2} \quad \dots\dots(6)$$

Let Q_a be the actual discharge, Then the coefficient of discharge, C_d is given by

$$C_d = \frac{Q_a}{Q_t} \quad \dots\dots(7)$$

$$Q_a = KC_d H^{5/2} \quad \dots\dots(8)$$

The co-efficient of discharge depends on relative head (H/P), relative height (P/B) and angle of the notch (θ)

From hydraulic point of view a weir may be fully contracted at low heads while at increasing head it becomes partially contracted. The flow regime in a weir is said to be partially contracted when the contractions along the sides of the V-notch are not fully developed due to proximity of the walls and bed of approach channel. Whereas a weir which has an approach channel and whose bed and sides of the notch are sufficiently remote from the edges of the V-notch to allow for a sufficiently great approach velocity component parallel to the weir face so that the contraction is fully developed is a fully contracted weir. In case of a fully contracted weir C_d is fairly constant for a particular angle of notch.

At lower heads, frictional effects reduce coefficients. For the most common angle of notch 90 degree, the discharge coefficient, C_d is about 0.6.

Apparatus

1. A constant steady water supply with a means of varying the flow rate.
2. An approach channel
3. A V-notch weir plate
4. A flow rate measuring facility
5. A point gauge for measuring H.

Procedure

1. Position the weir plate at the end of approach channel, in a vertical plane, with the sharp edge on the upstream side.
2. Admit water to channel until the water discharges over the weir plate.
3. Close the flow control valve and allow water to stop flowing over weir.
4. Set the point gauge to a datum reading.
5. Position the gauge about half way between the notch plate and stilling baffle.
6. Admit water to the channel and adjust flow control valve to obtain heads, H, increasing in steps of 1 cm.
7. For each flow rate, stabilize conditions, measure and record H.
8. Take readings of volume and time using the volumetric tank to determine the flow rate.

Objective

1. To find C_d for the V-notch.
2. To plot Q_t vs. Q_a in a plain graph paper.
3. To plot Q_a vs. H in a log-log paper and to find (a) the exponent of H and (b) C_d

Practice Questions

1. Why does the V-notch give more accurate flow measurement than any other weirs and orifices when the flow is slightly fluctuating?
2. What is the average value of C_d for a 90° V-notch? Does it depend on flow condition (partially or fully contracted)?
3. Determine the discharge of water over a 60° triangular weir if the measured head is 0.623 ft.



Experiment No. 7
FLOW OVER A V-NOTCH
 Observation and Calculation Sheet

Angle of the notch, $\theta =$ _____

$K =$ _____

Cross-sectional area of the measuring tank = _____

Initial point gauge reading = _____

Final point gauge reading = _____

Difference in reading = _____

Datum water level reading = _____

Water level above vertex = _____

Final water level reading = _____

| No. of Obs. | Vol. of water | Collection time T | Actual discharge Q_a | Effective head H | Theoretical discharge Q_t | Co-eff. of discharge |
|-------------|---------------|-------------------|------------------------|------------------|-----------------------------|----------------------|
| | | | | | | |

| | | | | | | |
|------------------------|--|--|--|--|--|--|
| No of observation | | | | | | |
| Actual discharge Q_a | | | | | | |
| Effective head H | | | | | | |
| Theoretical discharge | | | | | | |

U G V
 UNIVERSITY OF GLOBAL VILLAGE

 Signature of the Teacher

Note: Suitable unit must be provided in the data sheet.

Experiment No. 8

FLUID FRICTION IN A PIPE

General

Head loss in a pipe flow is mainly due to friction in pipes and again friction is due to roughness of pipes. It has been proved that friction is dependent not only upon the size and shape of the projection of roughness, but also upon their distribution or spacing.

Practical application

Flow through a single pipe line, pipes in series and parallel and also in pipe network system, the head loss has to be estimated. The head loss from source to the point of interest due to the friction along the pipe also provides the basis of pipe size (diameter) design. This experiment gives an estimate of head loss due to friction in the pipe per unit length of the pipe.

Theory

If the head loss in a given length of uniform pipe is measured at different values of the velocity, it will be found that, as long as the velocity is low enough to secure laminar flow. the head loss, due to friction, will be directly proportional to the velocity. But with increasing velocity, at some point where the visual observation in a transparent tube would show that the flow changes from laminar to turbulent, there will be an abrupt increase in the rate at which the head loss varies. If the logarithms of those two variables are plotted on linear scales or if the values are plotted directly on log-log paper, it will be found that, after a certain transition region has been passed, lines will be obtained with slopes ranging from about 1.75 to 2.00.

It is thus understood that for laminar flow the drop in energy due to friction varies as V , while for turbulent flow the friction varies as V^n , where n ranges from about 1.75 to 2.00. The lower value of 1.75 for turbulent flow is found for pipes with very smooth walls; as the wall roughness, the value of n increases up to its maximum value of 2.00

However, velocity is not the only factor that determines whether the flow is laminar or turbulent. The criterion is Reynolds number. For a circular pipe the significant linear dimension L is usually taken as the diameter D , and thus

$$R_e = \frac{VD}{\nu}$$

Head loss, h_L can be generalized as proportional with the exponential power of velocity, V by

$$h_L \propto V^n$$

where n is the exponent of velocity

Therefore, $h_L = KV^n$

where K is a constant.

Early experiment on the flow of water in long, straight, uniform circular pipes indicated that head loss varied (directly with velocity head and pipe length and inversely with pipe dia. Darcy Weisbach proposed the formula for the turbulent flow,

$$h_L = 4f \frac{L V^2}{D 2g}$$
$$\text{or, } f = \frac{D 2g}{4L V^2} h_L$$

Where, f=friction factor

$$\phi(R_e) = 0.079 R_e^{0.025}$$

Friction factor also depends upon the relative roughness.

For laminar flow head loss (h_L) given by Hagen-Poiseuille is

$$h_L = \frac{32\mu LV}{\rho g D^2}$$
$$\text{as } f = \frac{64}{R_e}$$

Therefore, friction factor (f) can be related empirically as

$$f = \phi(R_e)$$

$$= C R_e^m$$

Where m is the exponent of Reynolds number and C is a constant.

The striking feature of the equation is that it involves no empirical coefficient or experimental factors of any kind, except for the physical properties of fluid such as, viscosity, and density.

From this it would appear that in laminar flow the friction is independent of the roughness of the pipe wall.

Apparatus

1. Pipe friction apparatus
2. Stop watch
3. Discharge measuring facility
4. Thermometer.

Procedure

1. Measure the diameter of the pipe and distance between the two tapings.
2. Prime the mercury manometer.
3. Connect the test section pipe to the main water supply pipe.
4. Open flow control valve, priming test section and pipe work.
5. Open clips on water manometer, allowing water to circulate through the system until all the air is expelled.
6. Close pipe clips.
7. Bleed mercury manometer via bleed screws in conjunction with the control valves.
8. Close flow control valve.
9. Observe datum level on manometer.
10. To achieve maximum flow fully open flow control valve. Note levels in manometer and measure flow rate. Repeat for different control valve position.
11. When the mercury level is below 35 mm, open pipe clips near water manometer and take readings on both manometers, The level in the water manometer can be adjusted by operating the air valve or the hand pump.
12. For flows the constant head tank should be used as follows. Close control valve, close supply valve, disconnect inlet pipe from the bench and connect to constant head tank. Connect tank inlet to bench supply. Carefully open bench valve, fill head tank and adjust until water discharges from outlet pipe with flow control valve open. Take readings as before and measure flow rate. Measure the water temperature.

Objective

1. To find the frictional loss
2. To plot h_L vs velocity in log-log paper and determine the empirical relationship of the form $h_L = KV^n$.
3. To plot f vs. Re in a log-log paper and find the empirical relation of the form $f = CR_e^m$
4. To plot h_L vs velocity for turbulent flow condition and obtain an average value of f .

Practice Questions

1. What are the factors upon which the frictional loss in a pipe depends?
2. What is meant by critical Reynolds number?
3. What is a higher and lower critical point? Explain.
4. Write down the different types of losses that may occur in pipe flow.
5. An oil ($s=0.85$, $\nu=1.8 \times 10^{-5} \text{ m}^2/\text{s}$) flows in a 10 cm diameter pipe at 0.50 l/s. Is the flow laminar or turbulent?

Experiment No. 8
FLUID FRICTION IN A PIPE
 Calculation and Data Sheet

Diameter of the pipe, D = _____
 Area of the pipe, A = _____
 Temperature of water, t = _____
 $\rho =$ _____ . $\mu =$ _____ , $\nu =$ _____

| No of obs | Volume V_1 | Time T | Discharge Q | Velocity V | Reynolds No R_e | h_L m of H_g | h_L m of H_2O | f |
|-----------|--------------|--------|-------------|------------|-------------------|------------------|-------------------|---|
| | | | | | | | | |

| | | | | | | | |
|----------------------|--|--|--|--|--|--|--|
| No. of observation | | | | | | | |
| Discharge Q | | | | | | | |
| Velocity V | | | | | | | |
| Reynolds No. R_e | | | | | | | |
| h_L (m of H_2O) | | | | | | | |
| f | | | | | | | |

 Signature of the Teacher

Note: Suitable unit must be provided in the data sheet.



Experiment No. 9 HEAD LOSS DUE TO PIPE FITTINGS

General

In practical setting, fluid flows through different pipe fittings such as sudden contraction, sudden enlargement valve, elbow or bend, tee section etc. Sudden changes in the flow path result in secondary flow patterns, denoted as separation region and vena contracta (flow area contraction due to secondary flow). Vortices and eddies occur in these regions, consuming energy and resulting in an observable pressure drop. Large pressure drops are observed as the fluid is forced through non-streamlined passages. These losses through valves and fittings are known as minor losses or fitting losses. Due to separation of flow, the fluid energy reduces in the downstream of the component than the upstream.

Frictional losses are avoided here since the lengths of pressure measuring points (tapping points) are comparatively small.

Practical application

In any pipe network there may sudden change in pipe diameter, In any change in pipe diameter there is considerable head loss and we need to calculate the loss. From this experiment, we can determine the coefficient to calculate the losses.

Theory

Loss Due to sudden contraction

The loss of head in a sudden contraction is not only due to the contraction itself but also due to sudden expansion which follows the contraction as shown in figure.

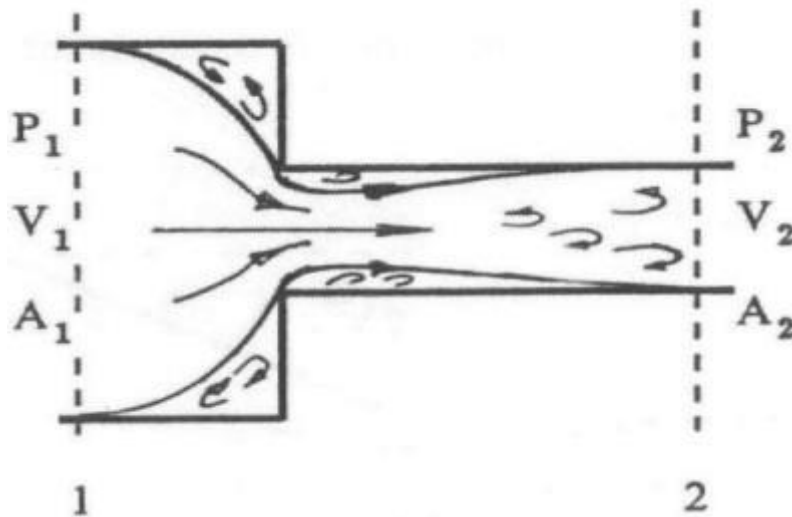

Figure 9-1: Sudden Contraction

$$\text{Head loss in sudden contraction } H_{LC} = \left(\frac{p_1}{\gamma} - \frac{p_2}{\gamma} \right) + \left(\frac{v_2^2}{2g} - \frac{V_1^2}{2g} \right)$$

Head loss in a sudden contraction expressed as $H_{LC} = K_C \frac{V_2^2}{2g} = k_1 V_2^n$

Where K_C is coefficient, which varies from 0.375 to 0.5. V_2 is the velocity of the contracted pipe.

Loss due to sudden expansion

The loss of head in a sudden contraction is due to the formation of eddies at the corner as shown in Figure.

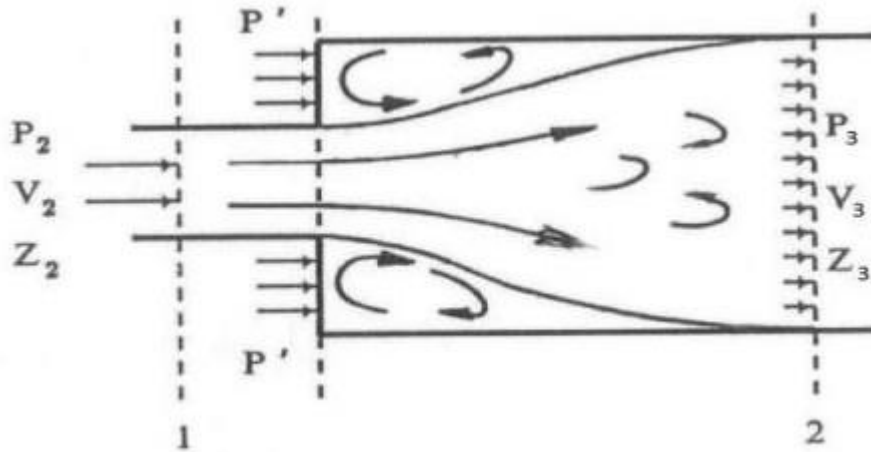

Figure 9-2: Sudden Expansion

Head loss in a sudden expansion $H_{LE} = \left(\frac{p_3}{\gamma} - \frac{P_2}{\gamma} \right) + \left(\frac{V_2^2}{2g} - \frac{V_1^2}{2g} \right)$

Head loss in a sudden expansion is expressed as $H_{LE} = K_E \frac{V_1^2 - V_2^2}{2g} = K_2 (V_2 - V_1)^n$

Where K_E is a coefficient which is equal to unity.

Experimental Setup

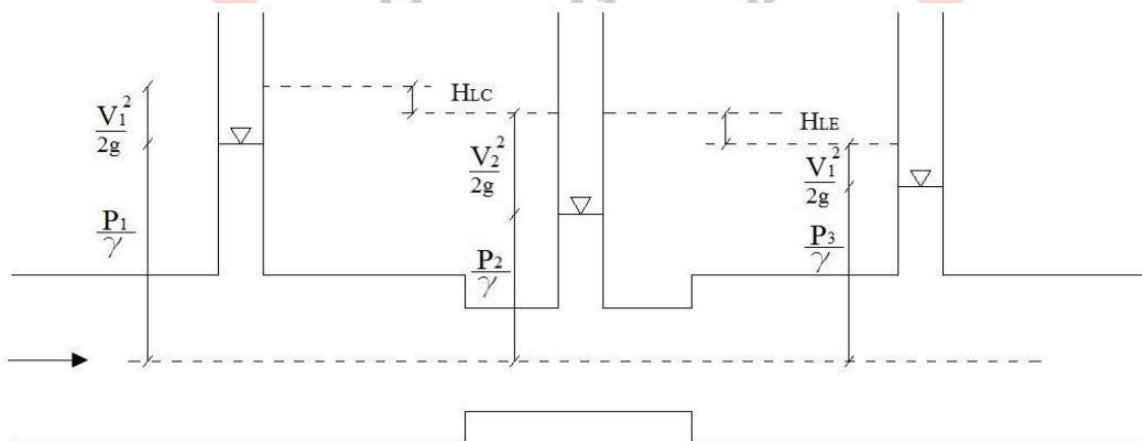

Figure 9-3: Sudden Contraction and Expansion

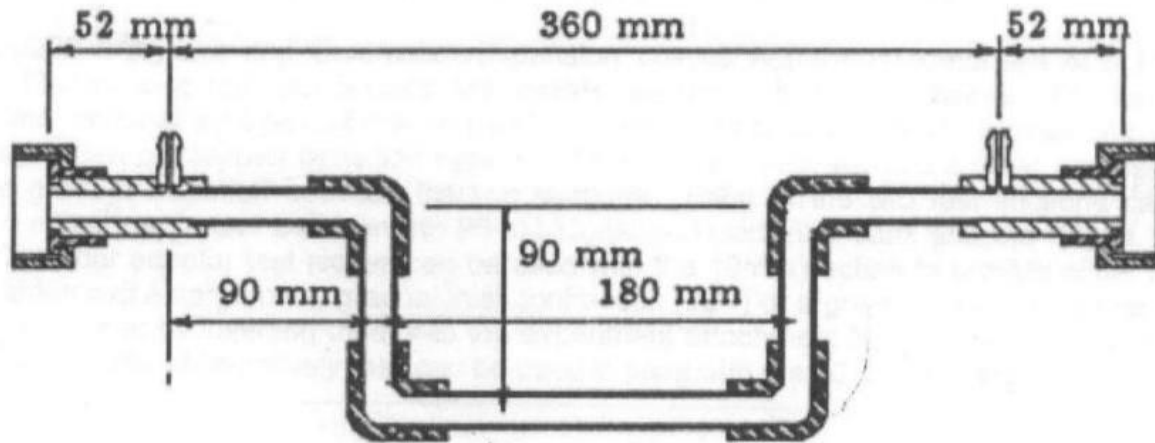

Figure 9-4: 10mm pipe with Four Elbows

Apparatus

1. Fluid friction apparatus
2. Stop watch
3. Discharge measuring facility
4. Thermometer

Procedure

13. Measure the diameter of the pipes.
14. Prime the mercury manometer
15. Connect the test section pipe to the main water supply pipe
16. Open flow control valve, priming test section and pipe work.
17. Open clips on water manometer, allowing water to circulate through the system until all the air is expelled.
18. Close pipe clips.
19. Bleed mercury manometers via bleed sewers in conjunction with control valves
20. Close flow control valve.
21. Observe datum level on manometers.
22. To achieve maximum flow fully open flow control valve. Note levels in manometer and measure flow rate. Repeat for different control valve position.
23. When the mercury level is below 35 mm open pipe clips near water manometer and take readings on both manometers. The level in the water manometer can be adjusted by operating the air valve or the hand pump.
24. For low flows the constant head tank should be used as follows. Close control valve, close supply valve, disconnect inlet pipe from the bench and connect to constant head tank. Connect tank inlet to bench supply. Carefully open bench valve, fill head tank and adjust until water discharges from outlet pipe with flow control valve open. Take readings as before and measure flow rate. Measure the water temperature.

Objective

1. To determine head loss due to sudden expansion and contraction.
2. To plot H_{LC} vs. V_2 in log-log paper and determine the exponent n and coefficient k_1
3. To plot H_{LE} VS (V_2-V_1) in log-log paper and determine the exponent n and coefficient k_2 .

Practice Questions

1. For the same diameter ratios and the same velocities the loss due to sudden expansion is greater than the loss due to a corresponding contraction. Explain why?



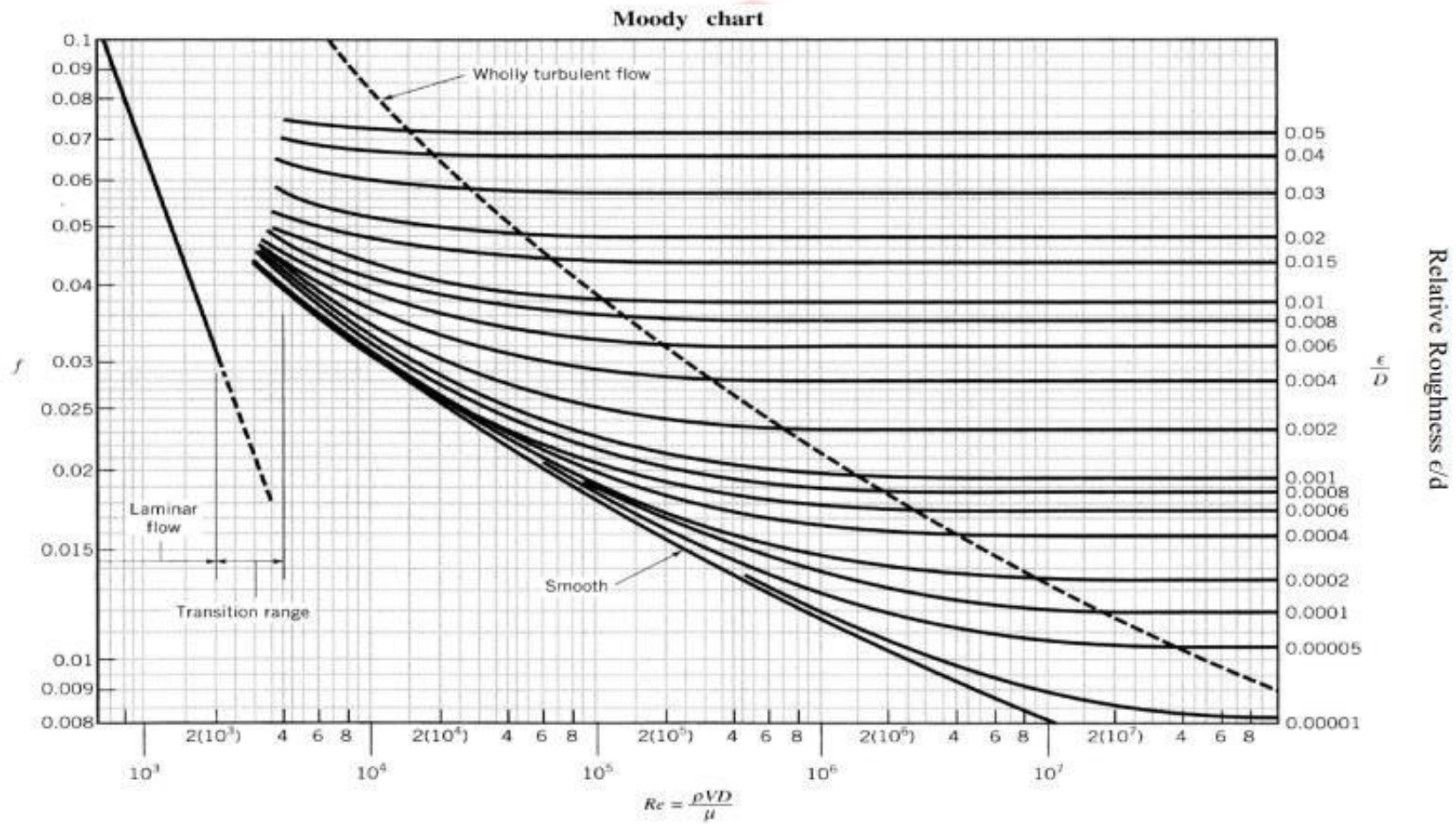

Friction factor as a function of Reynolds number and relative roughness for round pipes.



Figure 9-5: Stanton Diagram

Experiment No. 9
Calculation and Data Sheet

Diameter of pipe 1 D_1 =.....

Diameter of pipe 2 D_2 =.....

Area of pipe 1, A_1 =.....

Area of pipe 2, A_2 =.....

Volume of water V =.....

Collection time t =.....

Discharge=.....

| No of Obs. | Velocity V_1 | Velocity V_2 | H_1 (mm of Water) | H_2 (mm of Water) | Head loss due to Contraction H_{LC} | Head loss due to expansion H_{LE} |
|------------|----------------|----------------|---------------------|---------------------|---------------------------------------|-------------------------------------|
| | | | | | | |

| | | | | | |
|---------------------------------------|--|--|--|--|--|
| No. of observation | | | | | |
| Velocity V_1 | | | | | |
| Velocity V_2 | | | | | |
| Head loss due to contraction H_{LC} | | | | | |
| Head loss due to expansion H_{LE} | | | | | |

UNIVERSITY OF GLOBAL VILLAGE

Signature of the Teacher

Note: Suitable unit must be provided in the data sheet.

Loss due to Elbows:

Diameter of pipe, $D =$

Area of pipe, $A =$

Relative roughness, $\varepsilon/D =$

Reynolds Number, $R_e = VD/\nu =$

Volume of water, $V =$

Collection time, $t =$

Discharge, $Q_a =$

| No of Obs. | Velocity V (cm/sec) | H_1 (cm) | H_2 (cm) | Total head loss $h_L = H_1 - H_2$ (cm) | Friction factor, f' | Head loss due to Friction h_f (cm) | Head loss due to elbows, h_{elbows} (cm) |
|------------|-----------------------|------------|------------|--|-----------------------|--------------------------------------|--|
| | | | | | | | |

Note: Suitable unit must be provided in the data sheet

Appendix 1 Lab Report Format

1. All students must have a same colored printed **cover page**. The design of cover page is provided with the lab manual. Students have to compose only the course teacher's name and designation and their information.
2. An **index** is provided. It should be printed and set after the cover page. Table may be filled up by pen during each submission after that particular subject has been covered.
3. Each report must have a common **top page**. Only the experiment name and no. and the date may be filled up by pen. A top page design is provided.
4. **A4 papers** have to be used for preparing the lab report.

Thank You

University of Global Village (UGV), Barishal

Department of Mechanical Engineering

Prepared by

Md. Naeem Hosen Hredoy

Lab Instructor

Department of Mechanical

